

Audio Input Connections for Listen Everywhere

Overview:

This tech note is designed to assist with audio connections to the Listen Everywhere (LE) server. It reviews the audio input types for each model, balanced versus unbalanced audio connections, and wiring diagrams for connecting to terminal block connection types.

Audio Input Types:

Currently, the Listen Everywhere servers contain three audio input types: RCA (LW-100P) Dante RJ-45 (LW-150P) and terminal block (LW-100P and LW-200P). All model types have the option to play in stereo or monoaural. This selection can be adjusted within the Cloud Services management page. If not done already, an account can be registered [here](#).

If mono is desired, connect to a single terminal block input, or connect to one vertical pair of red and white RCA connections (LW-100P only). If stereo is desired, connect to a pair of terminal block inputs, or connect to one RCA input on the left and one RCA input on the right (LW-100P only). The LW-150 Dante connection handles both mono and stereo with the same connection. Connections to the terminal blocks are later outlined in the *Wiring Diagrams for Terminal Block Connections* section.

LW-100P



- ✓ RCA
- ✓ Terminal Block

LW-150P



- ✓ Dante (RJ-45)

LW-200P



- ✓ Terminal Block

Referenced below is a chart indicating the audio input specifications:

| | RCA | Terminal Block | Dante |
|---------------------|------------|----------------|----------|
| Connection Type | Unbalanced | Balanced | Balanced |
| Nominal Input Level | -10 dBu | + 4 dBu | +2 dBu |
| Clip | +2 dBu | +16 dBu | +16 dBu |
| Impedance | 100k ohm | 100k ohm | N/A |

Balanced Audio:

Balanced audio connection types are highly recommended for any audio runs because they are less susceptible to induce noise. They are denoted as a three-conductor connection, with a positive, negative, and ground wire. XLR and terminal block connectors are among the most common balanced audio connection types. The LE server comes equipped with terminal block connections so that balanced audio can be achieved.

In this connection, the signal runs along both a positive and a negative wire. However, the signal is inverted on the negative wire and is out of phase of the positive signal. Noise picked up on the cable run is introduced equally on both the positive and negative signals, making them in phase. As the signals arrive at the receiving device, the negative signal inverts back to being in phase with the positive signal. The noise that was introduced on the negative signal is also inverted, becoming out of phase with the noise on the positive signal. These two signals are then summed together. When two common signals which are out of phase are summed together, they will cancel out, referred to as "common-mode rejection."

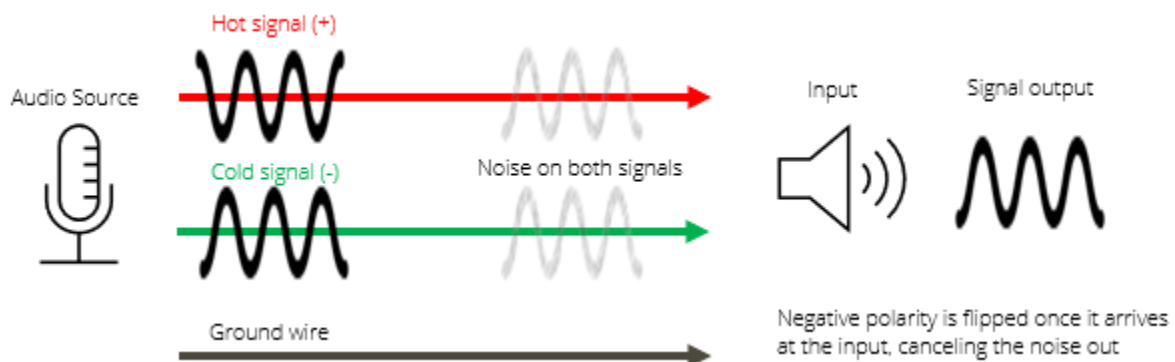

Unbalanced Audio:

Unbalanced audio connection types may be utilized if a balanced connection is not an option. It is recommended to use a balanced connection to avoid any unwanted noise. RCA cable connectors (tip-sleeve) connectors, and TS (tip-sleeve) connectors are common unbalanced audio connection types.

An unbalanced audio connection contains two wire designations: a signal and a ground. The signal wire will send the audio signal while the ground wire acts as both a reference point for the signal and an antenna, where unwanted noise can be picked up along its' path. Most commonly, this noise comes from power cables, electrical interference, and/or radio interference. You can reduce noise from an unbalanced connection by improving cable shielding, avoiding long cable runs (usually over 15ft), and by avoiding objects that can be picked up by the ground wire. If the audio connection will be close or next to any other cabling, it is best to run these cables perpendicular (\perp), instead of parallel ($||$).

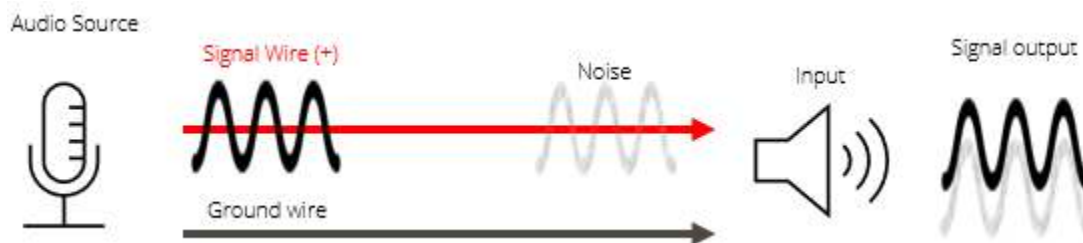

Dante Digital Signal:

The Dante protocol converts analog audio signals to lossless digital audio signals. This conversion prevents environmental interference that affects analog audio signals. Conversion from an analog audio source to a Dante audio signal is done by specialized devices. This is most commonly a digital mixing console or a dedicated analog to Dante conversion device.

Dante requires CAT 5E or higher Ethernet cable with a maximum distance of 100 meters.

For more information about Dante, please visit audinate.com

Stereo Vs. Balanced Connections:

It is a common misconception that a balanced cable is synonymous with a stereo cable. This happens because an unbalanced stereo cable can use the same jack type as a balanced mono connection, typically with TRS jack types. However, their properties are drastically different. The unbalanced stereo connection would have a left channel (tip), right channel (ring), and ground (sleeve) whereas a balanced connection is constructed with a positive (tip), negative (ring), and ground (sleeve). It is important to identify these connection types before attempting to wire to the LE server.

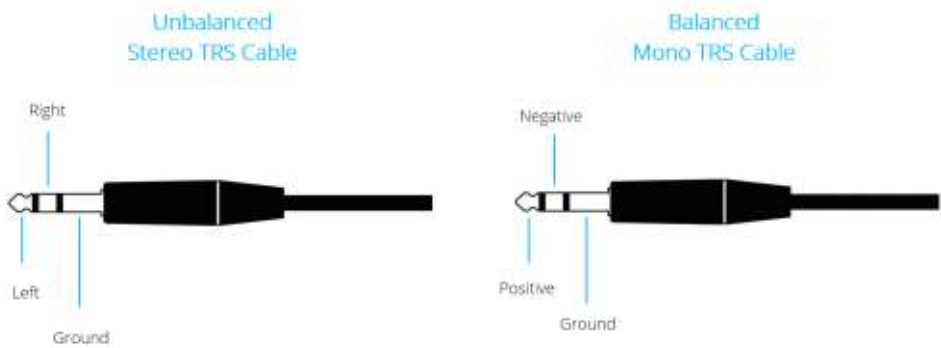

Wiring Diagrams for Terminal Block Connections:

The diagrams outlined in this section will assist with manually connecting different audio cables to the terminal block input connections. However, it's also possible to purchase adaptors that will fit into the terminal block connections, such as the [LA-507](#) XLR-F to Terminal Block Cable.

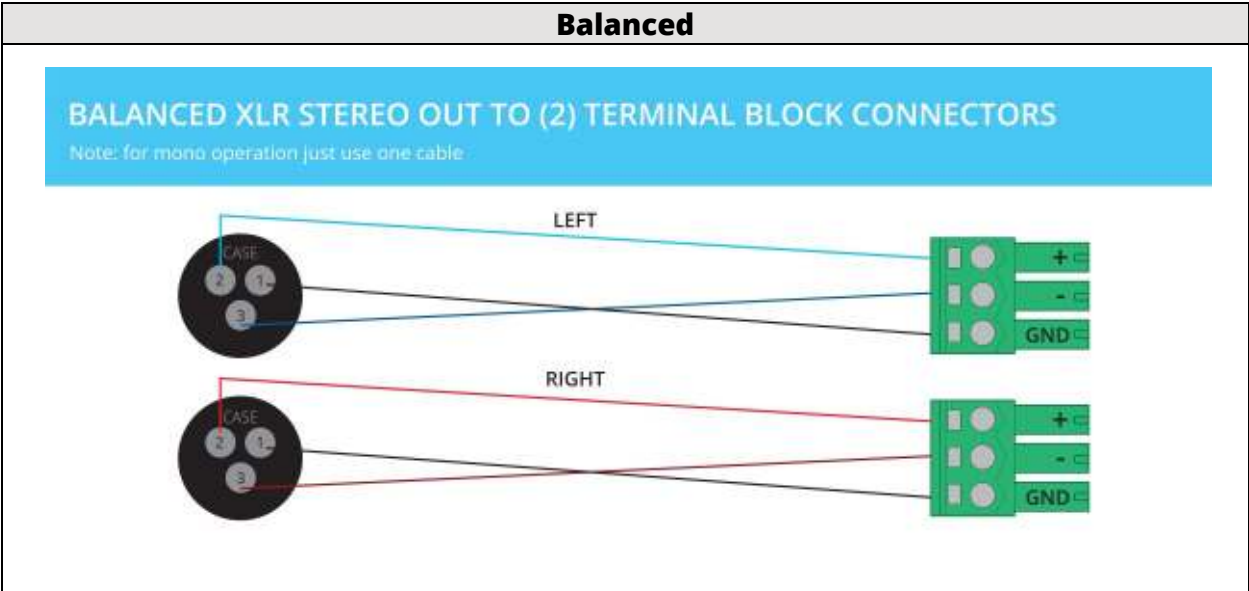

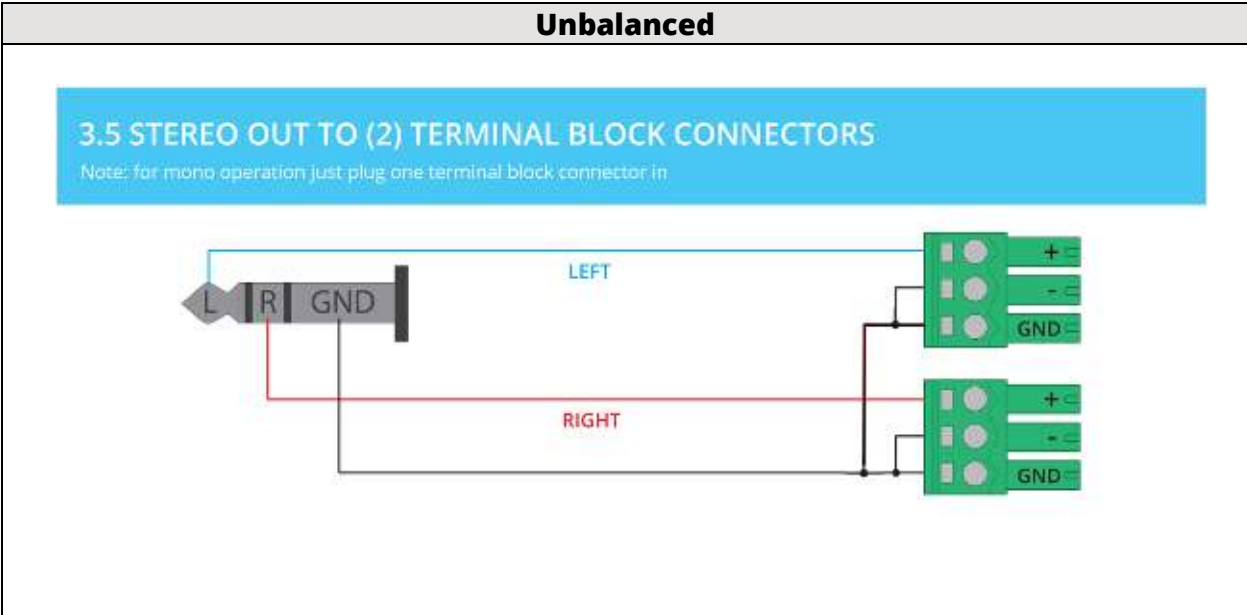
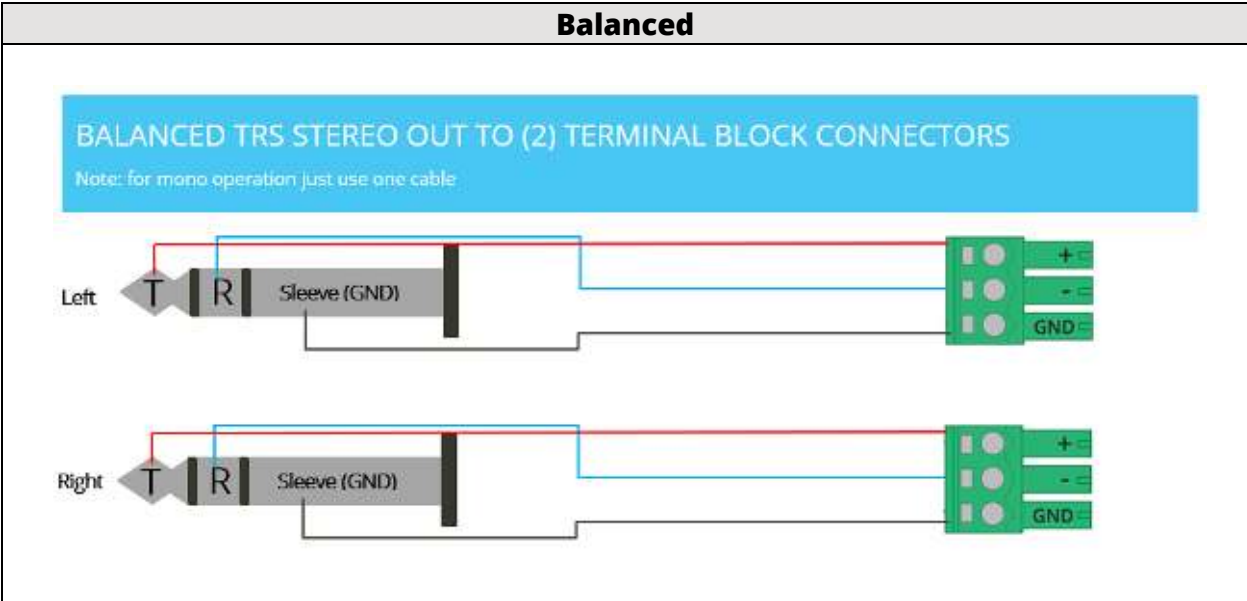

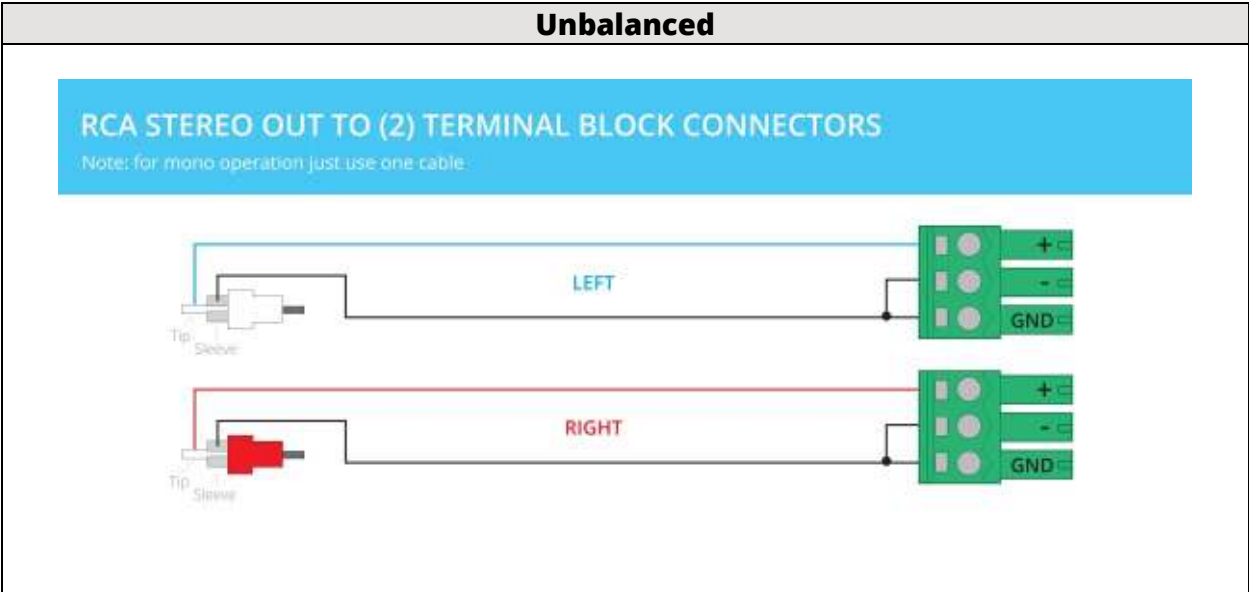

Should you have any further questions or concerns, please contact Listen Technologies' Technical Services team at 1-800-330-0891 or support@listentech.com for assistance.